

**WALL MOUNT
DETAIL**

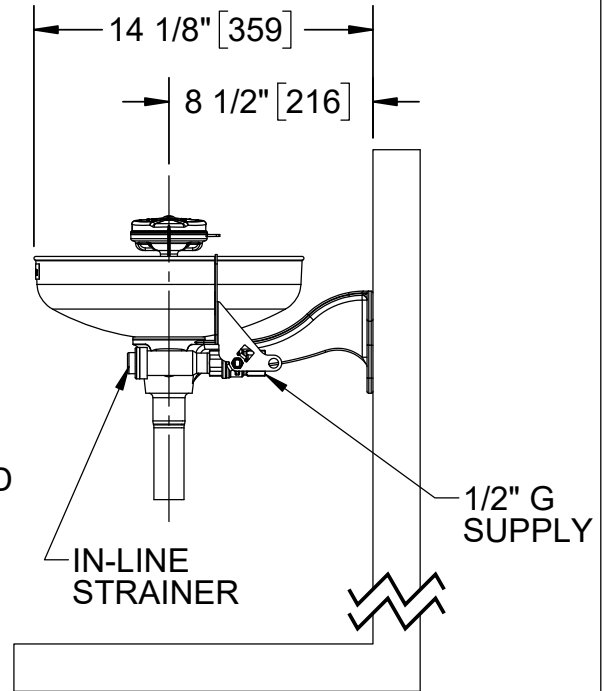
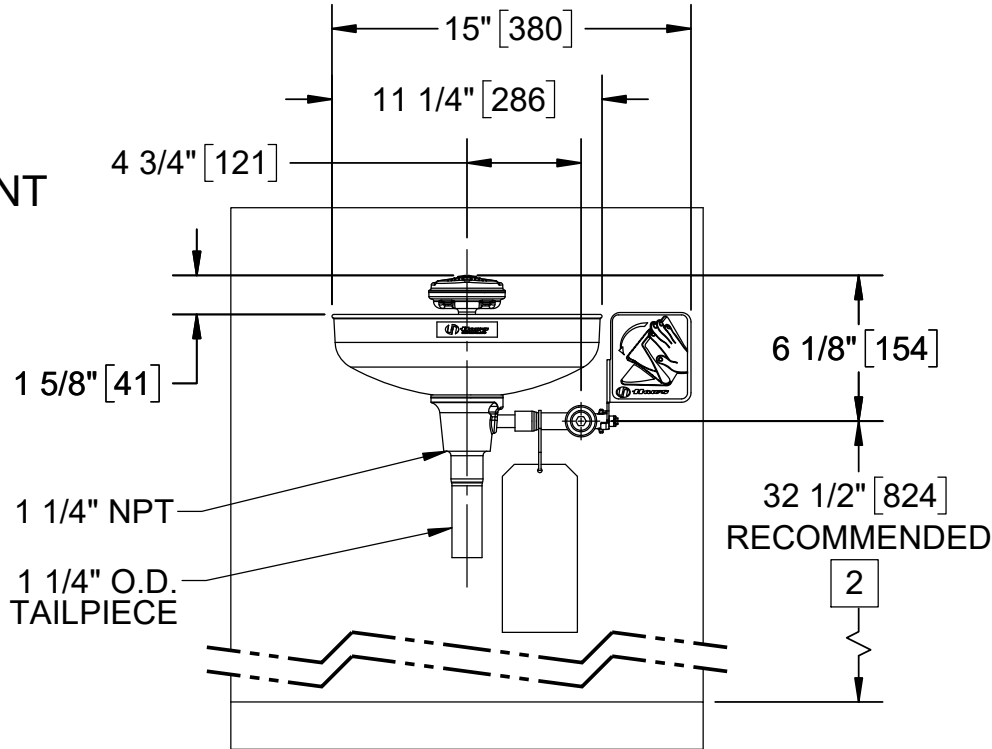
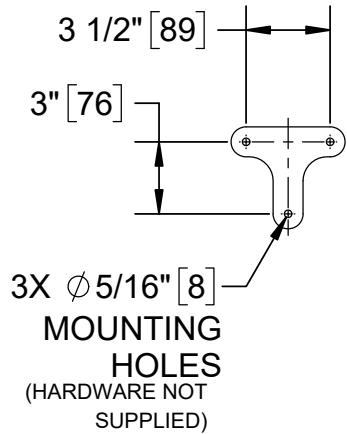

NOTES:

1. WHEN INSTALLING THIS UNIT, LOCAL CODES SHOULD BE ADHERED TO FOR INSTALLATION DIMENSIONS (LOCATIONS), WASTE AND SUPPLY REQUIREMENTS OTHER THAN SHOWN.

2. TO COMPLY WITH ANSI Z358.1-2014 FOR EMERGENCY EYEWASH OR EYE/FACE WASH: EYEWASH OR EYE/FACE WASH SHALL BE POSITIONED SUCH THAT FLUSHING FLUID PATTERN IS NOT LESS THAN 33" (838mm) AND NO GREATER THAN 53" (1346 mm) FROM SURFACE ON WHICH USER STANDS; AND 6.0" (153mm) MINIMUM FROM WALL OR NEAREST OBSTRUCTION .

TO COMPLY WITH DIN EN 15154-2 FOR PLUMBED-IN EYEWASH: EYEWASH SHALL BE POSITIONED SUCH THAT OUTLET NOZZLES ARE NOT LESS THAN 31.5" (800mm) AND NO GREATER THAN 47.24" (1200 mm) FROM SURFACE ON WHICH USER STANDS; AND 5.9" (150mm) MINIMUM FROM WALL OR NEAREST OBSTRUCTION.

3. DIMENSIONS MAY VARY BY ±1/2" (13 mm).

4. DIMENSIONS IN BRACKETS, IN DRAWING SPACE, ARE METRIC [mm].

ECN: 0001		REV. ECN: IR	BY: IR	MODEL(S)	PART NUMBER	
DRAWN: IR		DATE: IR	CHKD: IR	7260B AXION (10004428)	02080038.D	
APPROVED: IR		DATE: 11/12/2024	SCALE: 1:2.5	DRAWING TYPE: INSTALLATION	SIZE: A	REVISION
					1	
					SHEET 1 OF 1	



HAWS AG
BACHWEG 3
3400 BURGDORF SWITZERLAND
T +41 (0)34 420 60 00 F +41 (0)34 420 60 01
E-MAIL: INFO@HAWS.CH
WEBSITE: WWW.HAWS.CH

PARTS BREAKDOWN

ITEM	DESCRIPTION	MODEL NO.	ITEM NO.
1	AXION EYE/FACE WASH HEAD	SP65	10006249
2	FLOW CONTROL	SP37.5	10001711
3	DUST COVER	SP9091	10000718
4	BOWL	SP93	10006284
5	VALVE ASSEMBLY	SP229	10006167
6	BRACKET	SP80	10000288
7	INLINE STRAINER	SP509	10006227
8	REPAIR KIT FOR SP509	VRKEWSTR	10006353
9	TAILPIECE	SP95	10003425
10	EYEWASH SIGN	SP175	10003193
11	TEST TAG	SP170	10006134
--	FOOT TREADLE (NOT SHOWN)	SP220W	10006156

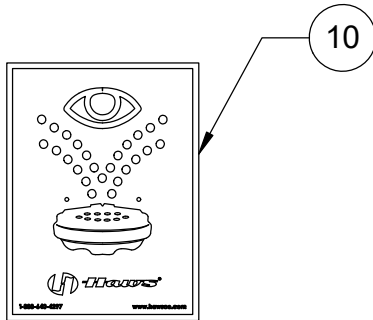

OPTIONAL -

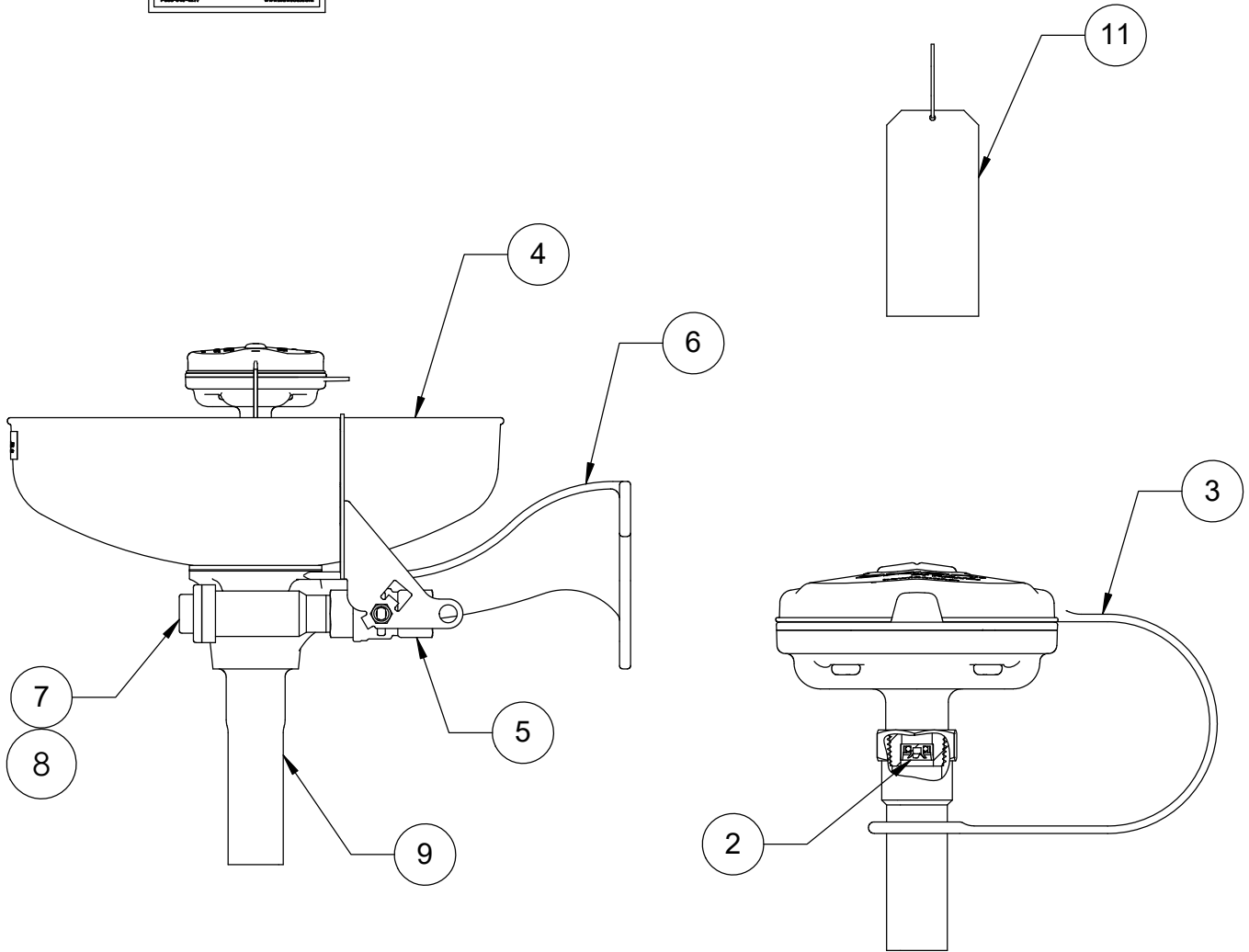

1 SP65 EYE/FACE WASH ASSEMBLY
(INCLUDES: EYE/FACE WASH HEAD, ADAPTER,
FLOW CONTROL, DUST COVER)

		HAWS AG BACHWEG 3 3400 BURGSDORF SWITZERLAND T +41 (0)34 420 60 00 F +41 (0)34 420 60 01 E-MAIL: INFO@HAWS.CH WEBSITE: WWW.HAWS.CH	
		ECN: 0001 REV. ECN: DRAWN: IR APPROVED: IR	BY: IR DATE: 11/24 DATE:
WHEN ORDERING PARTS, PLEASE SPECIFY ITEM NUMBER			
SCALE: NA		DRAWING TYPE: PARTS BREAKDOWN	
SIZE: A		SHEET 1 OF 1	