

**Model 8300FP Axion Eye Wash & Shower Freeze Proof** No.2080163/1

NOTE TO INSTALLER: please leave this information with the maintenance department.

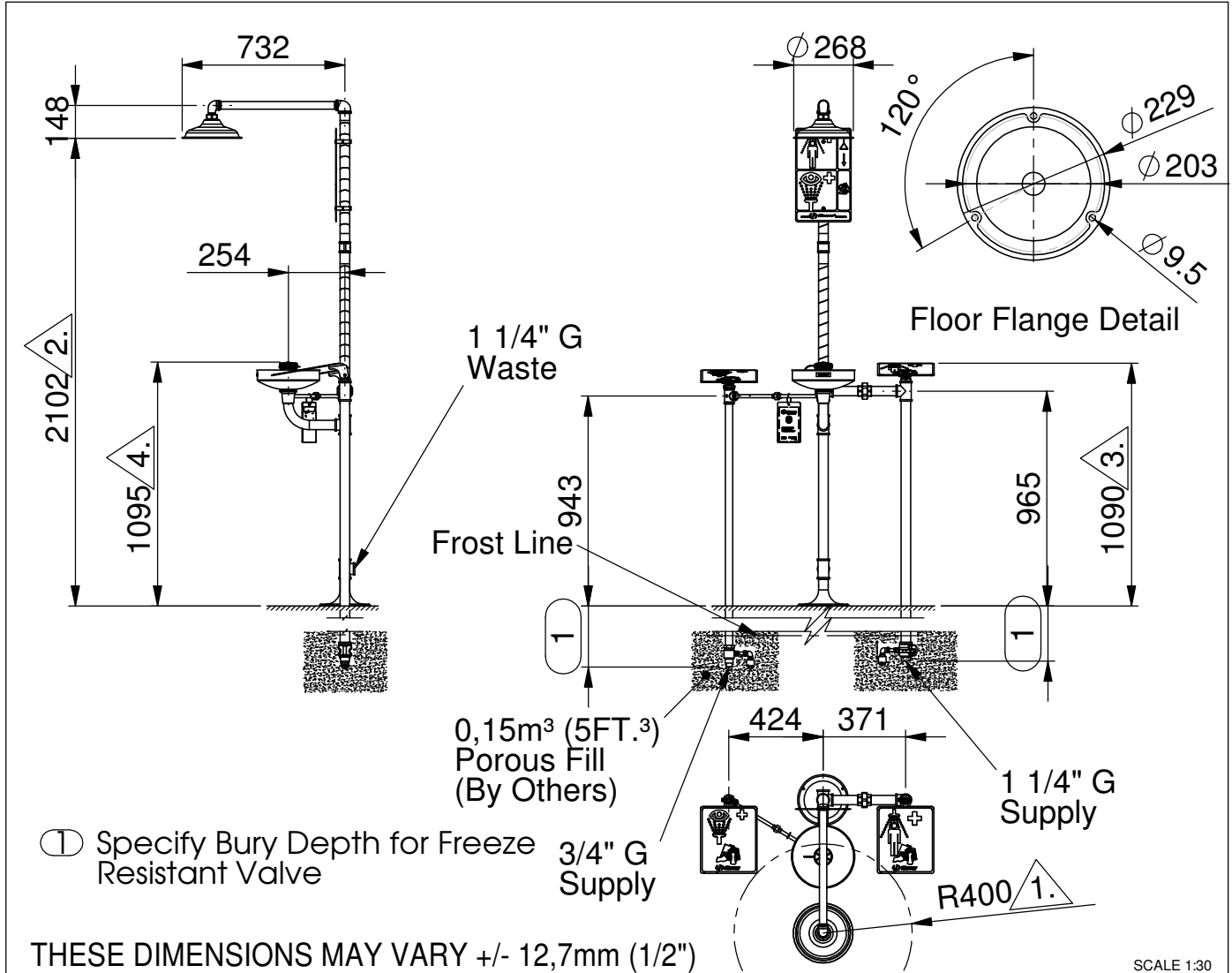

**Legally-stipulated dimensions:**

1. There must be a minimum clearance radius of 400 mm / 1' 3 3/4" (not counting operating controls and eyewasher units) between a vertical line running down from the shower head and the nearest obstacle (wall, vertical inlet pipe or similar).
2. Height above floor level: 2100mm - 2300mm (6' 10 1/2" - 7' 6 1/2").
3. The operating controls must be no higher than 1750mm (5' 9") above floor level (while conforming to local regulations).
4. Height above floor level: 800mm - 1200mm (2' 7 1/2" - 3' 11 1/4").

Free access to the eyewash station/body shower 8300FP Axion must be guaranteed at all times. The operator is responsible for the observance of this requirement.

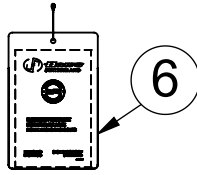
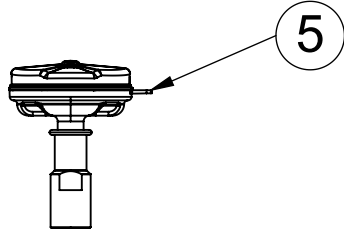

# PARTS BREAKDOWN

ITEM	PART NU.	DESCRIPTION
1	SP829	Axion shower head
2	SP178	Shower sign
3	SP75	Floor flange
4	MK8A	Freeze proof valve
5	SP65CTFP	Axion eye/face wash heads
6	SP170	Test tag
7	SP90	Bowl stainless steel
8	MK81A	Freeze proof valve
9	SP185	Stripe tape </td
10	SP218	Push plate with labels
11	SP82	Drain check valve

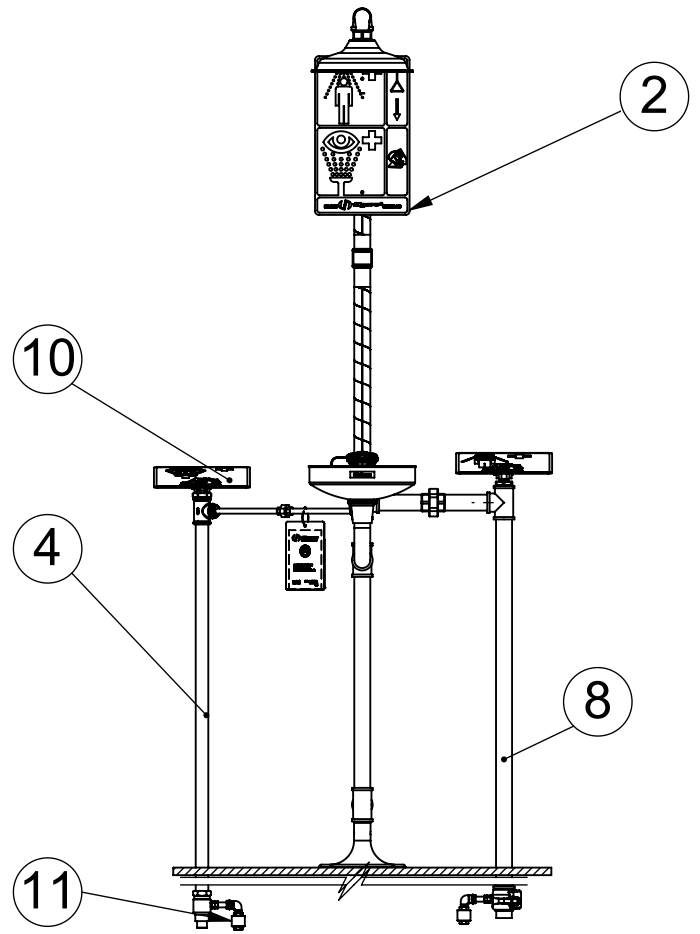
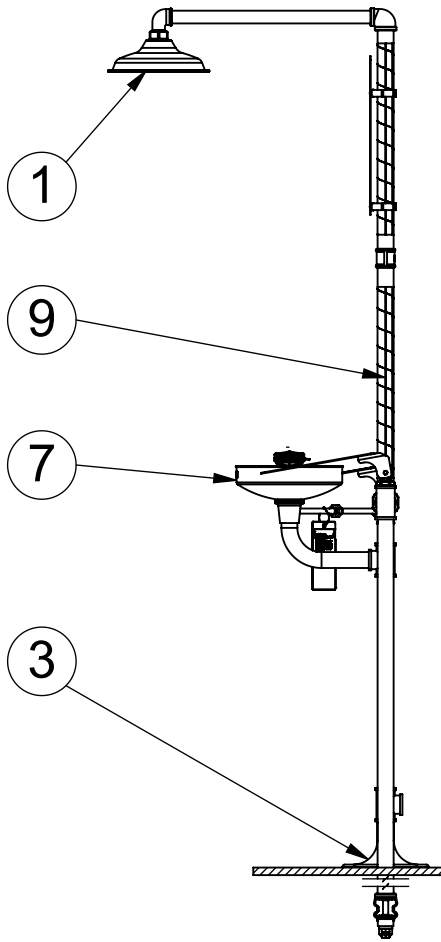

SP65CTFP EYE WASH ASSEMBLY



REV	DESCRIPTION	ECN NO.	DATE	BY
REVISIONS				
CATEGORY		MATERIAL		TITLE
 <p>T +41 (0)34 420 60 00 F +41 (0)34 420 60 01</p> <p>BACHWEG 3 CH3401 BURGENDORF SWITZERLAND</p> <p>www.haws.ch info@haws.ch</p>		SURFACE		WEIGHT (kg)
		APPROVALS		DATE
		MODELLED		29.05.2012
		DRAWN		29.05.2012
		REVISED		
CHECKED		bido	17.12.2019	SIZE
SCALE 1:20				DOCUMENT NO.
<p>THIS DOCUMENT AND THE DATA DISCLOSED HEREIN OR HEREWITH IS NOT TO BE REPRODUCED, USED, OR DISCLOSED IN WHOLE OR IN PART TO ANYONE WITHOUT THE PERMISSION OF HAWS CORPORATION.</p>		SHEET 2 OF 2		0012509
General tolerances ISO 2768-mK				REV.
				-